



# Super Energy-Saving Medium-Voltage AC Drive FSDrive-MV1000

3 kV CLASS, 200 kVA to 3700 kVA  
6 kV CLASS, 400 kVA to 7500 kVA  
11 kV CLASS, 660 kVA to 12000 kVA

# MV



**World's smallest  
MV drive**

**Global Standard**

Certified for  
ISO9001 and ISO14001



JQA-2800 JQA-EM0498

# Completely New: World's Smallest Medium-Voltage AC Drive Complies with Main Global Standards

## Compact, High-Performance, Energy-Saving, and User Friendly, delivers outstanding value.

In 1996, Yaskawa introduced Japan's first commercially produced medium-voltage drives with multiple outputs connected in series and continues development of energy saving and high-reliability technologies until today.

Yaskawa has led the industry in the field of low-voltage drives since our launch of the world's first transistor drive in 1974 by coming up with a series of groundbreaking technologies.

Now we are introducing completely new medium-voltage drives to our lineup, following the concept of amalgamating a medium-voltage drive with multiple outputs connected in series and a low-voltage drive.

These new drives comply with the main global standards and help energy-saving all over the world. Like a four-leaf clover that brings good luck, the FSDrive-MV1000 offers the four benefits of compactness, high performance, energy savings, and user friendliness.

Note: The smallest available 3-/4-/6-kV class products (according to survey by Yaskawa)

### An amalgamation of our accumulated technical capabilities and reliability.

#### Low-voltage drive

**G7** 7th generation low-voltage drive  
(The world's first general-purpose  
drive employing three-level control)

**1000 series**  
(J1000/V1000/A1000)



## FSDrive-MV1000

#### Medium-voltage drive

**VS-686HV5** ● 1996

Medium-voltage drive with multiple  
outputs connected in series  
(first commercial product in Japan)

**VS-686HV5S** ● 1998

**VS-686HV5SD** ● 2002

**FSDrive-MV1S** ● 2005

## CONTENTS

Features	4
Specifications	12
Dimensions and Model Numbers	13
Options	14
Application Examples	15
Standard Connections Diagram	18
Terminal Functions	19
Software Functions	20
Protective Functions	22
Drive Capacity Selection, Motors for Medium-Voltage Drives	23
Application Notes	24
Inquiry Form	26
Global Service Network	27

### 1 Compact Design

Significant downsizing and a draw-out design help this power cell facilitate transportation, installation, and maintenance.

Long-life and highly reliable parts have been stringently selected, and the circuit design simplified for compactness. Drives have evolved into more reliable and space saving FSDrive-MV1000 drives.

### 2 High Performance

Offering better performance, functionality, and reliability in low-and medium-voltage drives, and enabling stable continuous operation.

Equipped with functions unaffected by fluctuations in power supply and load. Input and output are both sinusoidal waves. FSDrive-MV1000 can be easily introduced into either new or existing facilities without any qualms.

### 3 Energy Saving

Promotes energy saving with highly efficient operation.

FSDrive-MV1000 realizes the highest levels of efficiency and power factor in the industry. Significant energy saving effects can be achieved.

### 4 User Friendly

Operation, adjustment, maintenance, and management are very easy, as with Yaskawa low-voltage drives.

FSDrive-MV1000 focuses on ease of use. Adopting the same user interface as Yaskawa low-voltage drives has made it easier to check the operating status and manage parameters.

### Global Standard

FSDrive-MV1000 provides an I/O voltage range from 2.4 kV to 11 kV and has been certified as being in accordance with the following global standards: UL\*1, CE\*2, and Gost

\*1 : For local production only.  
\*2 : For production dedicated to meet CE standards.



Note: Under application for approval.

# MV

## Compact Design

Significant downsizing and a draw-out design facilitates transportation, installation, and maintenance.

### 6-kV class Example Configuration of FSDrive-MV1000

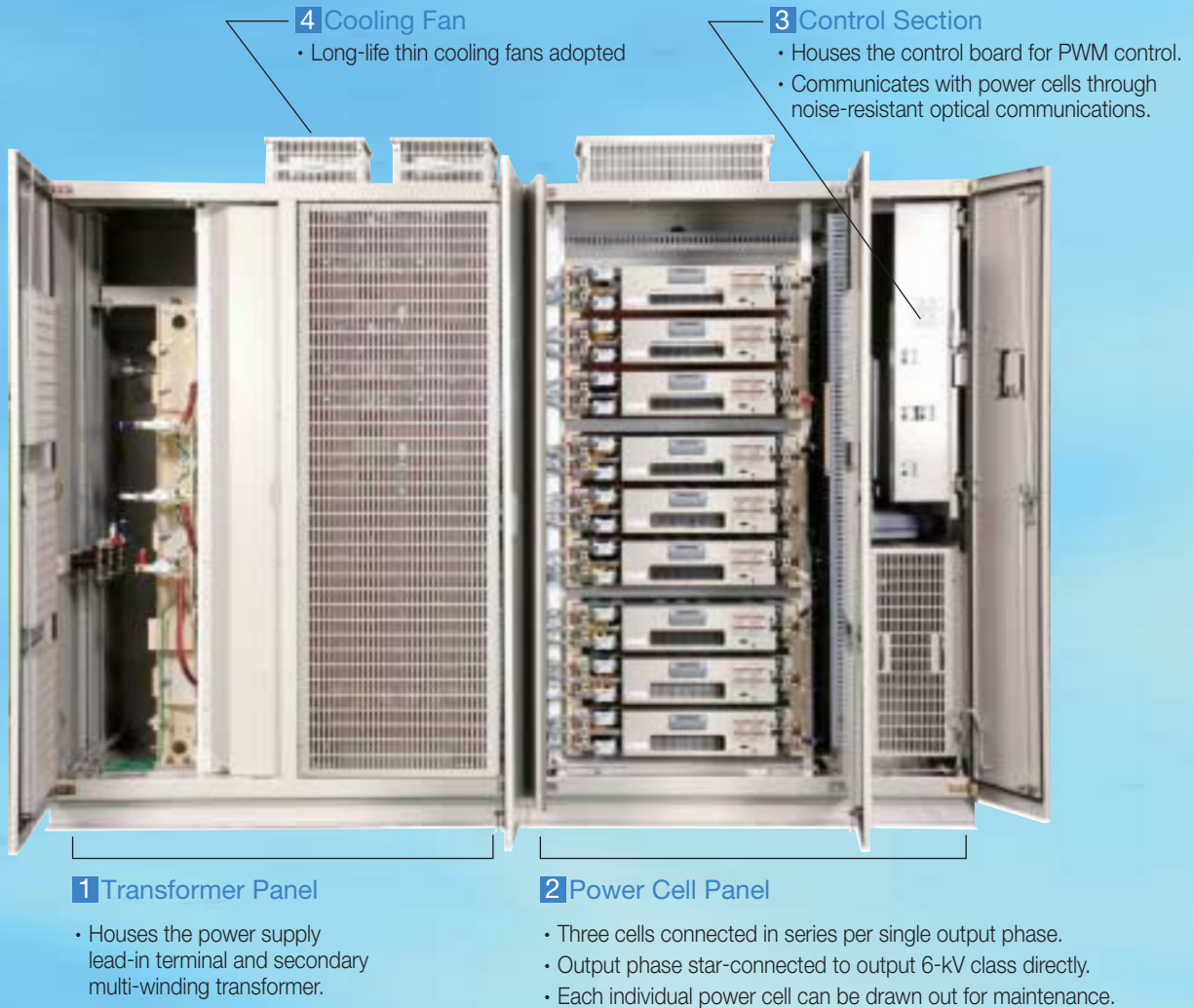

### Circuit Configuration

#### 6-kV class

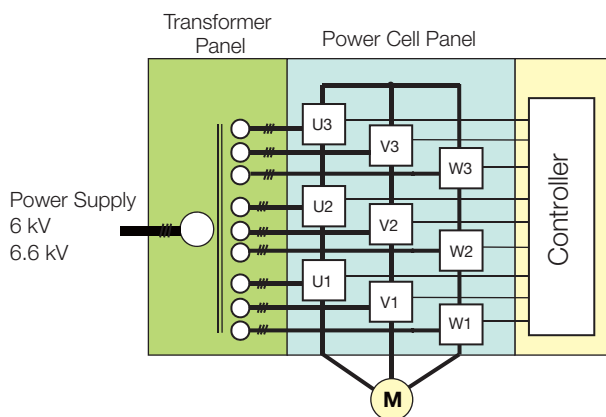

#### ● Configuration of One Power Cell

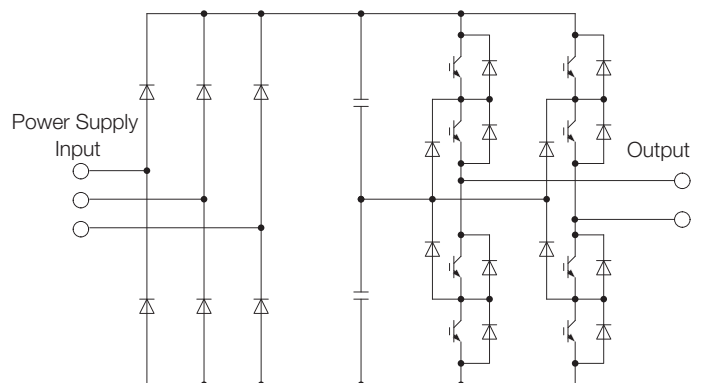

## Optimized Component Selection and Arrangement Reduces Volume Occupied by up to 60%!

### Minimal Height and Small Footprint

The compact design realized by developing thin power cells with three-level single phase output, and adopting a simple circuit configuration, a draw-out control panel and thin cooling fans, has resulted in a significant volume reduction of 30 to 60% when compared to the conventional Yaskawa product. The unit can even fit in a standard container for transportation\*.

\*: Restrictions might apply. Please contact Yaskawa for details.

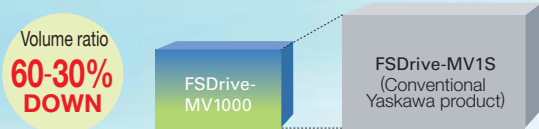

Everything has been done to achieve a small footprint, especially for 3-kV class drives (800 kVA or less), with the transformers located in the bottom of the panel and the power cells and controller at the top.

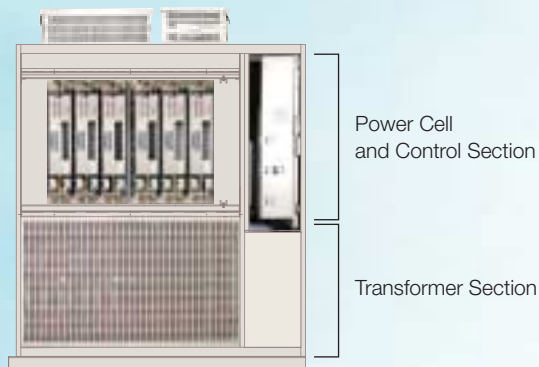

### Maintenance of Individual Power Cells

Power cells can be replaced and maintained individually. The construction designed for single-action mounting and removal reduces the replacement time and facilitates maintenance operations.



Power Cell



### 3-kV class

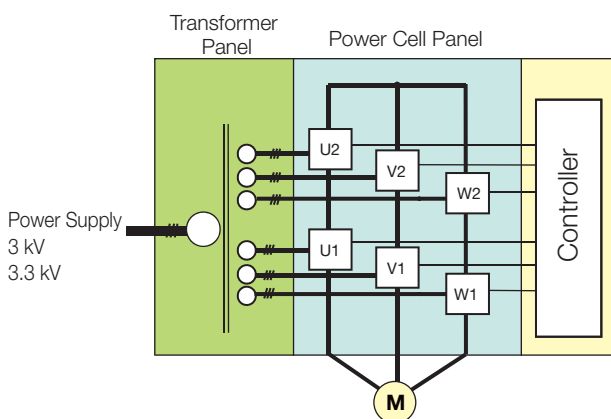

### 11-kV class

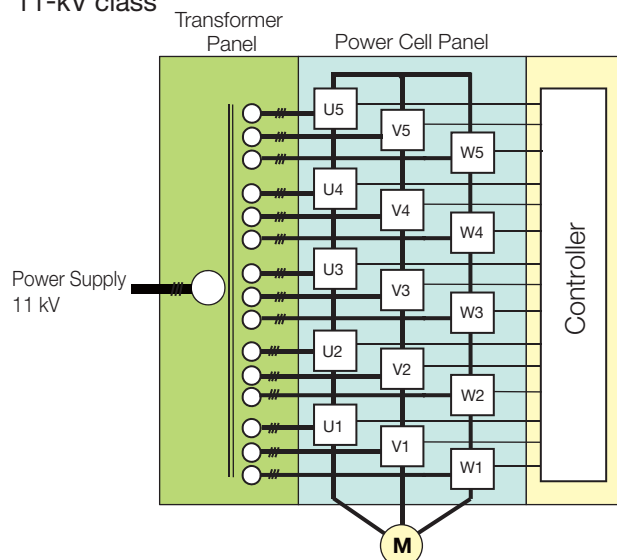

# MV

## High Performance

Offering better performance, functionality, and reliability in low- and medium-voltage drives, and enabling stable continuous operation.

Employs Open Loop Vector Control.  
Highly Resistant to Fluctuations in Power Supply and Load!

### High-level Control

Open Loop Vector control enables smooth acceleration from a low-speed range without using a speed detector. Operation is stable, unaffected by fluctuations in load. The high performance vector control drives synchronous motors as well as induction motors.

### Starting Characteristics

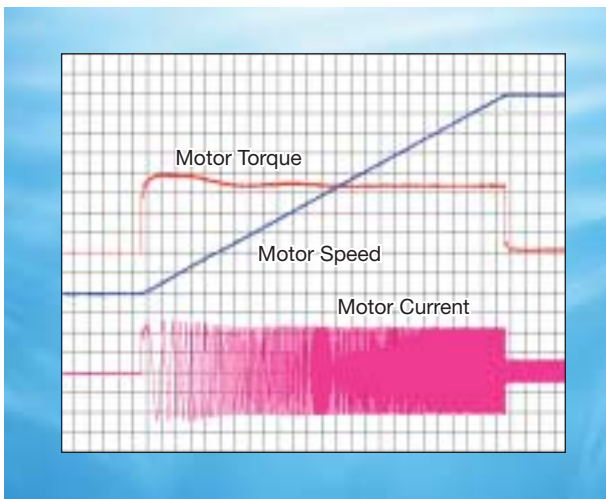

### Running Multiple Motors

The capability to run multiple induction motors in parallel with a single drive can reduce the size of the system as a whole.



Note: When running multiple motor operations, a protective device is required on each motor.

### Controlled and Secure Operation at Momentary Power Loss

FSDrive-MV1000 continues to operate for a number of cycles\*1 when a momentary power loss occurs, and re-accelerates to the reference speed immediately after the power is restored to ensure a smooth system start-up.

\*1: The retention time varies depending on the types of load and operation status.

### Speed Search Function

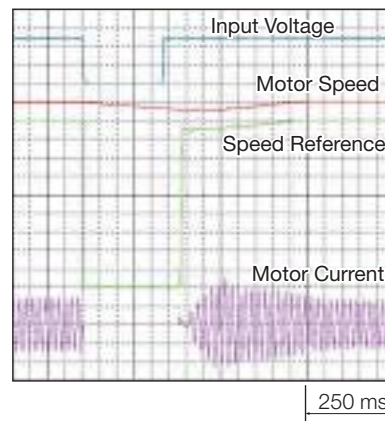

### KEB Function\*2

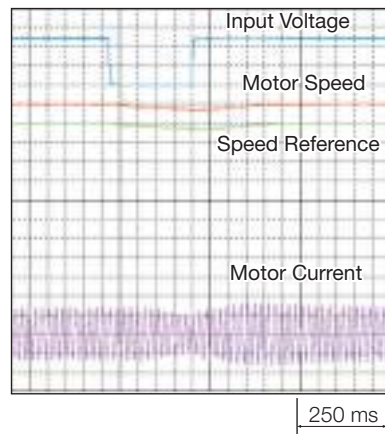

\*2: KEB (Kinetic Energy Back-up) Function: Function to continue operation without baseblocking during a momentary power loss.

## Incorporates Yaskawa's Smart Harmonics Technology and PWM Control with Multiple Outputs Connected in Series. Sinusoidal Input and Output Waves Ensure Easy Introduction at Facilities!

### Minimized Harmonics Comply with Guidelines

Yaskawa's original smart harmonics technology incorporated in FSDrive-MV1000 drastically cuts input harmonics. The resulting input waveform is sinusoidal, making it possible to clear the harmonics control guideline specified by the Ministry of Economy, Trade and Industry, and by IEEE519-1992, as an individual drive. This means that no harmonics filter or active filter is necessary. (Conducted a harmonics test in the presence of an authority from a global certification organization.)

### Measured Harmonics in Input Current

(For 3.3 kV, 630 kW, 60 Hz, full-load contract demand of 630 kW)

	5th	7th	11th	13th	17th	19th	23rd	25th	29th	31st
IEEE519	4.00	4.00	2.00	2.00	1.50	1.50	0.60	0.60	0.60	0.60
Guideline*	4.00	2.80	1.80	1.50	1.10	1.00	0.90	0.80	0.80	0.80
FSDrive-MV1000 Measured Value	1.00	0.60	1.40	0.90	0.10	0.20	0.40	0.20	0.30	0.10

\*: Guideline of the Ministry of Economy, Trade and Industry (Unit: %)

### Easily Applicable to Existing Motors

PWM control with multiple outputs connected in a series outputs sinusoidal wave voltage.

This has the following benefits:

- Free from oscillation surge voltage affecting the motor
  - Low torque ripple, easing the load
  - Noise as low as commercial power supply operation
- These benefits make it possible to use the existing motors and wiring cables without adding filters or other modifications.



The simple configuration for running standard high voltage motors directly realizes highly efficient operation with minimal loss due to input/output voltage transformers.

### Input Waveform

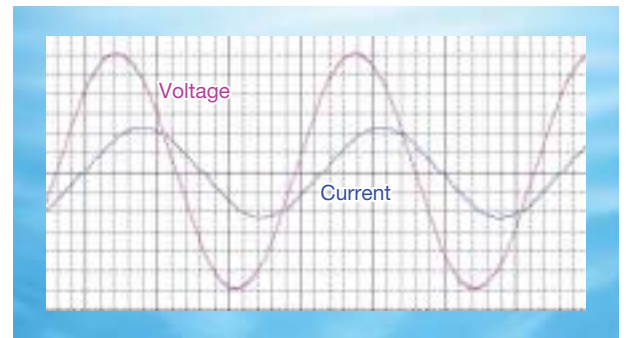

### Output Waveform

Line-to-Line Voltage (for 6-kV Class Drives)

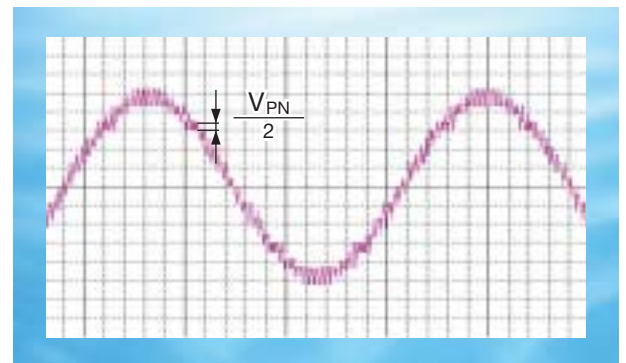

Phase Voltage (For Single Power Cell)

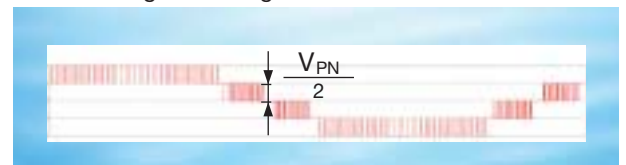

Note:  $V_{PN}$ : DC bus voltage for a single power cell

# MV

## Energy Saving

Promotes energy saving with highly efficient operation.

### World's Highest Standard of Performance Reduces Power Wastage!

#### High Efficiency and High Power Factor

Since FSDrive-MV1000 is a direct medium-voltage drive that does not need an output transformer, it can maintain a power conversion efficiency of approximately 97% over a wide speed range and secure a power supply factor of 0.95 (at rated load), avoiding energy wastage.

#### Power Conversion Efficiency Ratio

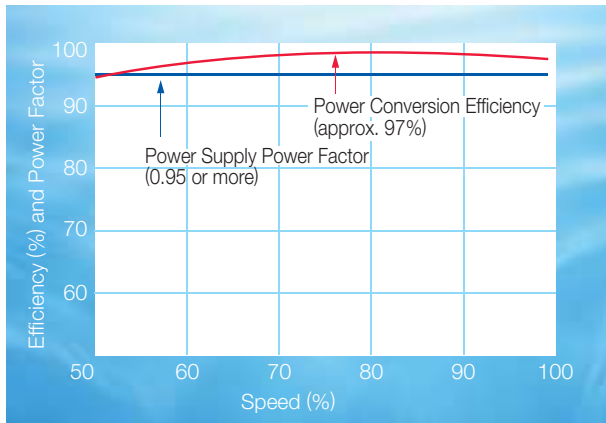

#### Energy Saving by Speed Control

The shaft power of wind and hydraulic machines such as fans, blowers, and pumps is proportional to the cube of the rotational speed.

Since drives maintain high efficiency even at low speed, a significant energy saving effect can be expected by using drives for wind and hydraulic machines and operating them at lower speeds.

#### Example: Calculation Formulae for Energy Saving Effects with Fans and Blowers

Power Consumption with Damper Control

$$P_d \text{ (kW)} = \frac{P_0}{\eta_{f0} \eta_{m0}}$$

$P_0$  : Motor rated power  
 $\eta_{f0}$  : Fan rated efficiency  
 $\eta_{m0}$  : Motor rated efficiency

Power Consumption with Drive Control

$$P_i \text{ (kW)} = \left( \frac{Q}{Q_0} \right)^3 P_0$$

$Q/Q_0$  : Ratio of air flow to fan rating  
 $P_0$  : Motor rated power  
 $\eta_f$  : Fan efficiency  
 $\eta_m$  : Motor efficiency  
 $\eta_i$  : Drive efficiency

#### Power Consumption Characteristic Curve

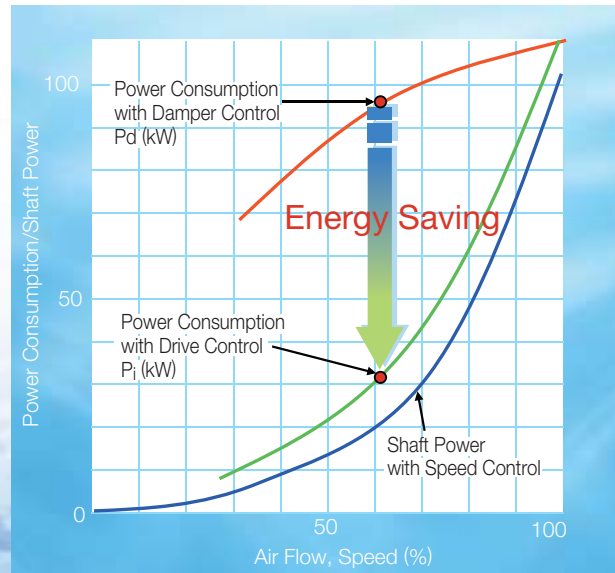



# MV

User Friendly

Operation, adjustment, maintenance, and management are very easy, as with Yaskawa low-voltage drives.

## Employs the Same User Interfaces as Yaskawa's 1000 Series Low-voltage Drives

### Easy-to-use User Interfaces

A Digital Operator with an easy-to-view LCD display (the same as used on Yaskawa's 1000 series low-voltage drives) is provided on the front panel as standard, making it easy to operate and set the drive.

The engineering tool DriveWizard Plus MV enables consolidated management of the parameters for each drive and makes for easy adjustment and maintenance.

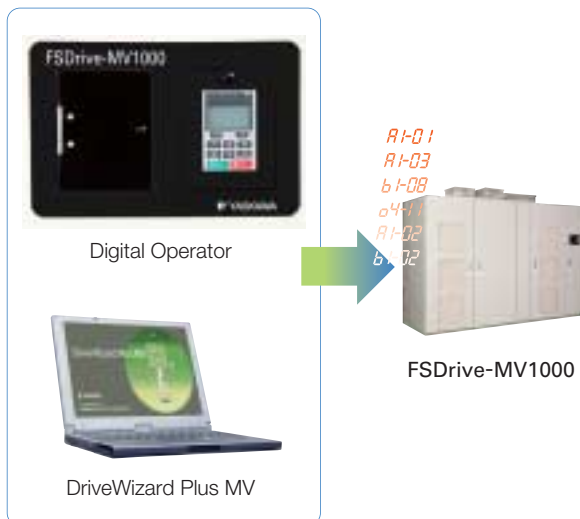

➔ Refer to pages 10 and 11 for details.

### Compatible with World's Major Field Network Protocols

The RS-485 communication function (MEMOBUS/Modbus protocol) is installed as standard. By adding an optional communication card, the major field network protocols can be supported. Achieve centralized control of production equipment and fewer connecting cables by connecting the drive to host computer or PLC.

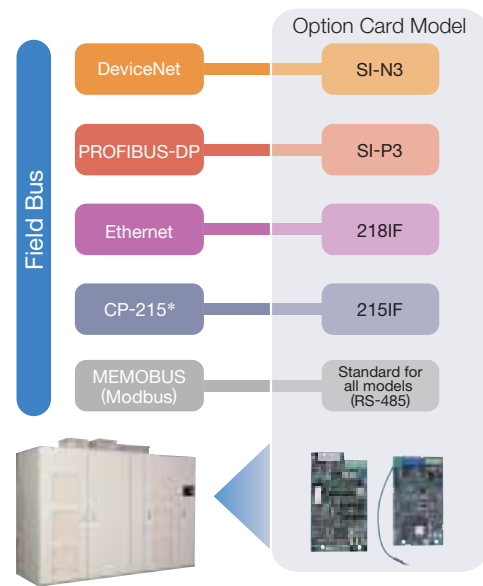

\*: Yaskawa's dedicated communication protocol

Note: Product names are trademarks or registered trademarks of the companies concerned.

## USB Copy Unit (Model: JVOP-181)

Enables the copying and transfer of parameters between drives using simple operations. This unit can also be used as a conversion connector between the communication port (RJ-45) of an drive and a USB port of a PC.

Note: No USB cable is needed to copy parameters to other drives.

### Connection



# MW

## User Friendly

An “Digital Operator” is Installed as Standard to Facilitate Configuration, Operation, and Monitoring.

### User-friendly Digital Operator

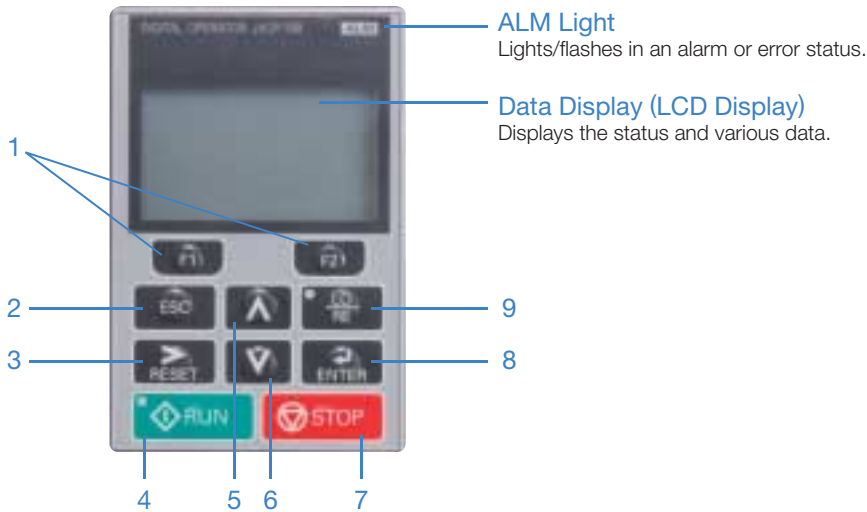

#### Key Names and Functions

No.	Key	Name	Function
1	F1 F2	Function Key (F1/F2)	The functions assigned to F1 and F2 vary depending on the currently displayed menu. The name of each function appears in the lower half of the LCD display window.
2	ESC	ESC Key	<ul style="list-style-type: none"> <li>Returns to the previous display.</li> <li>Moves the cursor one digit to the left when setting parameter numbers.</li> <li>Pressing and holding this button returns to the Frequency Reference display.</li> </ul>
3	RESET	RESET Key	<ul style="list-style-type: none"> <li>Moves the cursor one digit to the right when setting parameter values, etc.</li> <li>Resets the drive to clear a fault situation.</li> </ul>
4	RUN	RUN Key	Starts drive operation.
		RUN LED	Lit or flashing while the drive is running.
5	Up Arrow	Up Arrow Key	<ul style="list-style-type: none"> <li>Scrolls up to display the next item.</li> <li>Increments the parameter number or the setting value.</li> </ul>
6	Down Arrow	Down Arrow Key	<ul style="list-style-type: none"> <li>Scrolls down to display the previous item.</li> <li>Decrements the parameter number or the setting value.</li> </ul>
7	STOP	STOP Key	Stops drive operation. Note: The drive can be stopped in an emergency stop status by pressing  when danger is detected even if the drive is operating in the REMOTE mode in accordance with Run commands other than from the digital operator. To disable emergency stop operation using , set parameter o2-02 (STOP key function selection) to 0 (disabled).
8	ENTER	ENTER Key	<ul style="list-style-type: none"> <li>Enters the selected operation mode, parameter number and setting value.</li> <li>Selects a menu item to move between displays.</li> </ul>
9	LO/RE	LO/RE Selection Key	Switches the control of the drive between the digital operator (LOCAL mode) and an external source (REMOTE mode) for the Run command and frequency reference. Note: When there is a danger that the operation of the drive may be disrupted by erroneously switching the operation mode from REMOTE to LOCAL, disable  by setting parameter o2-01 (LO/RE selection key function selection) to 0 (disabled).
		LO/RE LED	Lit while the operator is selected to run the drive (LOCAL mode).

#### Drive operation status and relevant RUN LED indications

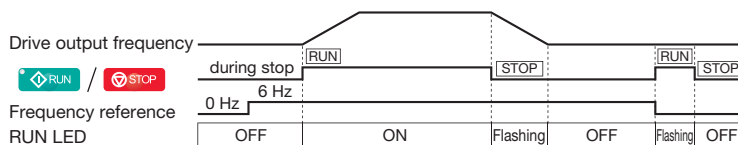

## “DriveWizard Plus MV” Supports Adjustment and Maintenance Tasks.

### Providing Support with a Variety of Functions

DriveWizard Plus MV enables consolidated management of the parameters for each drive on your PC. A variety of functions including monitoring, parameter editing, pattern operation, and oscilloscope functions, facilitates adjustment and maintenance of the drives. In addition, the extensive trace and event log functions enable implementation of preventive maintenance and a quick response in case of trouble.



#### System Requirements

PC	IBM PC compatible computers Note: Operation on NEC PC9821 series computers is not guaranteed.
CPU	Pentium 1GHz or higher (1.6 GHz recommended)
Main Memory	1 GB or greater
Available Hard Disk Space	In the standard setup configuration: • 100 MB or greater (400 MB or greater recommended at time of installation)
Display Resolution	XGA monitor (1024 × 768 or higher, use “Small Fonts”.)
Number of Colors	65535 colors (16 bits) or greater
OS	English or Japanese operating system (32-bit OS only) • Windows 2000 Service Pack 1 or later • Windows XP • Windows Vista • Windows 7
Others	More than one RS-232, RS-485 or USB port CD-ROM drive (only for installation) Adobe Reader 6.0 or later Note: Adobe Reader is required to display the help information.

Note: Pentium is a registered trademark of Intel Corporation.  
Windows 2000/XP/Vista/7 are registered trademarks of Microsoft Corporation.

#### Trace

The Trace function acquires the drive data under the set conditions and displays it in graph form. You can investigate the drive operations in detail.

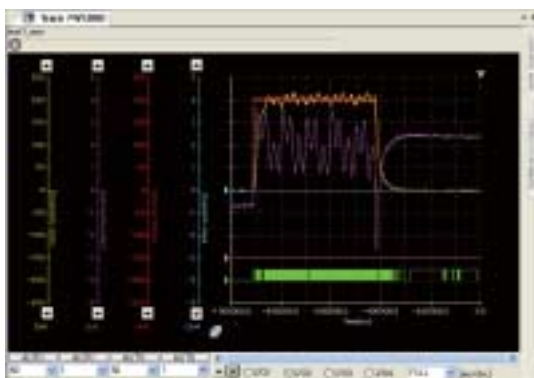

#### Parameter Edit

Displays and edits drive parameters.

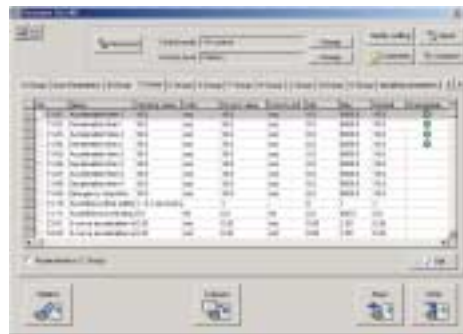

#### Auto-tuning

Automatically adjusts the motor-related parameters.



#### Troubleshooting

Checks the faults that have occurred on the drive. Causes are quickly investigated by tracing fault status and the corrective actions are displayed.



#### Oscilloscope

Displays the monitor data in real time while the drive is running.



# Specifications

## Model-Specific Specifications

Model	CIMR-MV2A□□□□	035	050	070	100	140	200	260	330	400	520	650	
Nominal Capacity	3-kV Class Output	kVA	200	285	400	570	800	1150	1500	1900	2300	3000	3700
	Max. Applicable Motor Capacity	kW	132	200	315	450	630	900	1250	1500	1800	2500	3000
Output Rating	Rated Output Current	A	35	50	70	100	140	200	260	330	400	520	650
	Rated Output Voltage	V	Three-phase, 3000 V or 3300 V (sinusoidal wave, proportional to input voltage)										
Power Supply	Main Circuit	Three-phase, 3000 V (50 Hz ± 5%) or 3300 V (50/60 Hz ± 5%) –20% to +10%											
	Control Circuit	Single-phase, 200/220 V 50/60 Hz ± 5%											
Model	CIMR-MV2A□□□□	035	050	070	100	140	200	260	330	400	520	650	
Nominal Capacity	6-kV Class Output	kVA	400	570	800	1150	1600	2300	3000	3800	4600	6000	7500
	Max. Applicable Motor Capacity	kW	250	400	630	900	1250	1800	2500	3000	3600	5000	6000
Output Rating	Rated Output Current	A	35	50	70	100	140	200	260	330	400	520	650
	Rated Output Voltage	V	Three-phase, 6000 V or 6600 V (sinusoidal wave, proportional to input voltage)										
Power Supply	Main Circuit	Three-phase, 6000 V (50 Hz ± 5%) or 6600 V (50/60 Hz ± 5%) –20% to +10%											
	Control Circuit	Single-phase, 200/220 V 50/60 Hz ± 5%											
Model	CIMR-MV2A□□□□	035	050	070	100	140	200	260	330	400	520	650	
Nominal Capacity	11-kV Class Output	kVA	660	950	1300	1900	2650	3800	5000	6200	7600	9900	12000
	Max. Applicable Motor Capacity	kW	530	760	1070	1520	2130	3050	3960	5030	6100	7930	9910
Output Rating	Rated Output Current	A	35	50	70	100	140	200	260	330	400	520	650
	Rated Output Voltage	V	Three-phase, 10000 V, 10500 V or 11000 V (sinusoidal wave, proportional to input voltage)										
Power Supply	Main Circuit	Three-phase, 10000 V, 10500 V or 11000 V (50/60 Hz ± 5%) –20% to +10%											
	Control Circuit	Single-phase, 200/220 V 50/60 Hz ± 5%											

## Common Specifications

Efficiency	Approx. 97% (At rated motor speed, 100% load)	
Power Factor	Min. 0.95 (At motor rated speed, 100% load)	
Cooling Method	Forced air-cooling by fan (with failure detection)	
Control Specifications	Control Method	Open-loop vector control, Closed loop vector control, V/f control (for multiple motor operation), Closed loop vector control for SM (option)
	Main Circuit	Voltage-type PWM control with multiple outputs connected in series (power cell: 3-level output)
	Freq. Control Range	0.01 to 120 Hz
	Freq. Control Accuracy	±0.5%
	Analog Input Resolution	0.03 Hz
	Accel/Decel Time	0.1 to 6000 s
	Torque Accuracy*1	±0.5% (open-loop vector control), ±3% (closed loop vector control)
	Overload Tolerance	Continuous rated current 100%, overload tolerance 110% for 1 minute and 120% for 15 seconds
	Momentary Power Loss Compensation Time*2	Max. 2 seconds
Main Control Functions	Torque control, Droop control, Speed/torque control switch, Momentary power loss compensation, Speed search, Overtorque detection, Torque limit, 17-step speed (max.), Accel/decel time switch, S-curve accel/decel, 3-wire sequence, Auto-tuning (rotational, stationary), Dwell, Cooling fan on/off, Slip compensation, Torque compensation, Frequency jump, Upper/lower limits for frequency reference, DC injection braking at start and stop, High slip braking, PID control (with sleep function), Energy saving control, MEMOBUS communication (RS-485, max. 115.2 kbps), Fault retry	
Protective Functions	Overcurrent, Overvoltage, Undervoltage, Output ground fault, Output open-phase, Overload, Cooling-fan error, Transformer overheat, Motor overheat, etc.	
PLC Functions	Expansion PLC board (option)	
Communications (optional)*3	Any one of PROFIBUS-DP, DeviceNet, Ethernet, or CP-215 can be installed.	
Input Transformer	Class H dry type, –5%/N/+5% tap, secondary multi-phase winding	
Temperature Protection	Power cells: protected by thermistor for temperature Transformer: protected by thermometer PT100Ω	
Maintainability/Environmental Specifications	Control Panel	Status display, Fault display, Parameter setting, Parameter reference
	Main Circuit	Power cell construction
	Protection Design	IP40 (simplified dustproof type)
	Ambient Temperature, Relative Humidity	–5°C to +40°C, 85%RH max. (no condensing)
	Storage Temperature	–20°C to +60°C (for very short term when handling)
Atmosphere	General environmental conditions, free from dust and corrosive gases Altitude: Max. 2000 m	
Panel Specifications	Painting	5Y7/1 semi-gloss both for inner and outer faces
	Form	Made of enclosing steel sheets, vertical standalone type, front maintenance type
Applicable Standards	JIS, JEM, JEC	

\*1: Adjustments, e.g. to parameters, are required after auto-tuning.

\*2: When the momentary power loss compensation function is used, an uninterruptible power supply unit for the control power supply is needed (this is an option).

\*3: To use the communications function, additional wiring and the installation of an option card must be done. For Ethernet or CP-215 communication, an optional expansion PLC board is required.

Note: Contact Yaskawa regarding 2.4 kV/4.16 kV power supply for the main circuit.

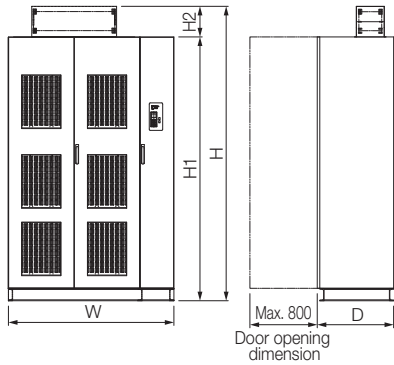

Fig.1

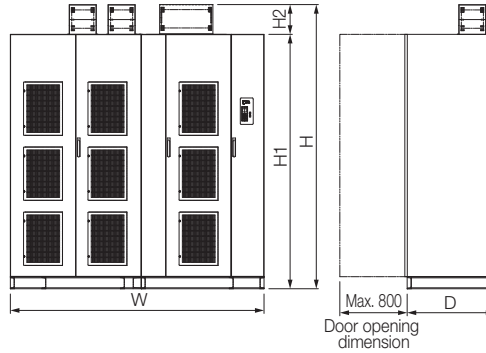
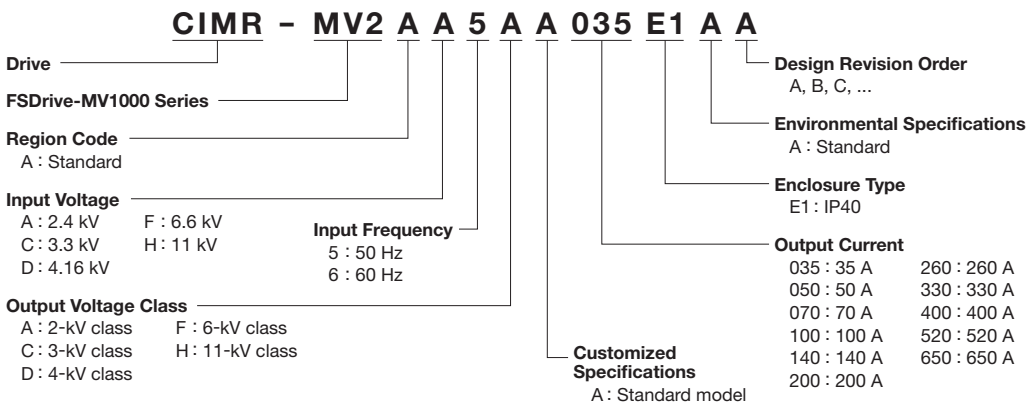

Fig.2

Voltage Class (kV)	Model CIMR-MV2A	Capacity kVA	Current A	Dimensions mm					Approx. Mass kg	Figure
				Width W	Depth D	Height H	Height H1	Height H2		
3	C□CA035	200	35	1950	1000	2550	2150	400	2100	Fig.1
	C□CA050	285	50	1950	1000	2550	2150	400	2200	
	C□CA070	400	70	1950	1000	2550	2150	400	2400	
	C□CA100	570	100	1950	1000	2550	2150	400	2600	
	C□CA140	800	140	1950	1000	2550	2150	400	2800	Fig.2
	C□CA200	1150	200	3000*	1100	2550	2150	400	4100	
	C□CA260	1500	260	3500*	1200	2550	2150	400	5500	
	C□CA330	1900	330	4100*	1600	2550	2150	400	7000	
	C□CA400	2300	400	4100*	1600	2550	2150	400	7400	
C□CA520	3000	520	5300*	1600	2800	2400	400	8800		
C□CA650	3700	650	5600*	1600	2800	2400	400	9900		
6	F□FA035	400	35	3100*	1100	2550	2150	400	3000	Fig.2
	F□FA050	570	50	3100*	1100	2550	2150	400	3300	
	F□FA070	800	70	3100*	1100	2550	2150	400	3600	
	F□FA100	1150	100	3100*	1100	2550	2150	400	3900	
	F□FA140	1600	140	3100*	1100	2550	2150	400	4200	
	F□FA200	2300	200	4500*	1300	2550	2150	400	6600	
	F□FA260	3000	260	5500*	1300	2550	2150	400	8000	
	F□FA330	3800	330	6300*	1600	2800	2400	400	10100	
	F□FA400	4600	400	6300*	1600	2800	2400	400	11000	
F□FA520	6000	520	7100*	1600	2900	2400	500	14500		
F□FA650	7500	650	7300*	1600	2900	2400	500	17000		
11	H□HA035	660	35	5100*	1400	2700	2400	300	7600	Fig.2
	H□HA050	950	50	5100*	1400	2700	2400	300	7800	
	H□HA070	1300	70	5100*	1400	2700	2400	300	8000	
	H□HA100	1900	100	5100*	1400	2700	2400	300	8200	
	H□HA140	2650	140	5100*	1400	2700	2400	300	8400	
	H□HA200	3800	200	6900*	1500	2700	2400	300	10000	
	H□HA260	5000	260	7300*	1600	2800	2400	400	13200	
	H□HA330	6200	330	8800*	1700	2800	2400	400	16000	
	H□HA400	7600	400	8800*	1700	2800	2400	400	17000	
	H□HA520	9900	520	10200*	1800	2900	2400	500	22000	
H□HA650	12000	650	10200*	1800	2900	2400	500	25000		

\* : Block construction  
 Note: The dimensions and masses may be changed.

## Model Numbers



Note: All input voltage are not necessarily compatible with all output voltage classes.

# Options

Type	Name	Function	Manual No.
Built-in Type (connected to connector)	Speed (Frequency) Reference Card	Analog Input AI-A3 Enables high-precision and high-resolution analog speed reference setting. · Input signal level: -10 to +10 Vdc (20 kΩ) 4 to 20 mA (500 Ω) · Input channels: 3 channels (DIP switch for input voltage/input current selection) · Input resolution: Input voltage 13 bit signed (1/8192) Input current 1/6554	TOBPC73060038
		Digital Input DI-A3 Enables 16-bit digital speed reference setting. · Input signal: 16 bit binary, 4 digit BCD + sign signal + set signal · Input voltage: +24 V (isolated) · Input current: 8 mA User-set: 8 bit, 12 bit, 16 bit	TOBPC73060039
	Communications Card*1	DeviceNet Interface SI-N3 Used for running or stopping the drive, setting or referencing parameters, and monitoring output frequency, output current, or similar items through DeviceNet communication with the host controller.	TOBPC73060043 SIJPC73060043
		PROFIBUS-DP Interface SI-P3 Used for running or stopping the drive, setting or referencing parameters, and monitoring output frequency, output current, or similar items through PROFIBUS-DP communication with the host controller.	TOBPC73060042 SIJPC73060042
		CP-215 Interface 215IF Used for running or stopping the drive, setting or viewing parameters, and monitoring output frequency, output current, etc. through CP-215 communication with the host controller. CP-215 communication system is a high-speed, real-time, N: N network with shared-memory and handling both cyclic and message transmissions. An expansion PLC board is needed to use the CP-215.	Under development
		Ethernet (CP-218) Interface 218IF Used for running or stopping the drive, setting or viewing parameters, and monitoring output frequency, output current, etc. through CP-218 communication with the host controller. CP-218 communication system is a type of Ethernet that supports communication with the MEMOBUS protocol, non-protocol, or MELSEC protocol. An expansion PLC board is needed to use the CP-218.	Under development
	Monitor Card	Analog Monitor AO-A3 Outputs analog signal for monitoring drive output state (output freq., output current etc.). · Output resolution: 11 bit signed (1/2048) · Output voltage: -10 to +10 Vdc (non-isolated) · Terminals: 2 analog outputs	TOBPC73060040
		Digital Output DO-A3 Outputs isolated type digital signal for monitoring drive run state (alarm signal, zero speed detection, etc.) · Terminals: 6 photocoupler outputs (48 V, 50 mA or less) 2 relay contact outputs (250 Vac, 1 A or less 30 Vdc, 1 A or less)	TOBPC73060041
	PG Speed Controller Card*2	Complementary Type PG Interface PG-B3 For control modes requiring a PG encoder for motor feedback. · Phase A, B, and Z pulse (3-phase) inputs (complementary type) · Max. input frequency: 50 kHz · Pulse monitor output: Open collector, +24 V, max. current 30 mA · Power supply output for PG: +12 V, max. current 200 mA	TOBPC73060036
		Line Driver PG Interface PG-X3 For control modes requiring a PG encoder for motor feedback. · Phase A, B, and Z pulse (differential pulse) inputs (RS-422) · Max. input frequency: 300 kHz · Pulse monitor output: RS-422 · Power supply output for PG: +5 V or +12 V, max. current 200 mA	TOBPC73060037
PLC Function	Expansion PLC Board BC-620 Supplements PLC functions required to customize the drive. · Program memory capacity: Equivalent to 8,000 steps · Execution speed: 1,000 steps/1 ms · Language: Ladder language	Under development	
Panel Housed Type	Momentary Power Loss Compensation Uninterruptible Power Supply Unit UPS is installed inside the panel and backs up a control power supply when momentary power losses occur. This option is required to implement measures against momentary power loss (for the speed search function or KEB function).	-	
	Backup Cooling Fan Automatically enables continued operation of the drive in case of one of the cooling fans fails to operate. (N + 1 backup system)	Under development	
	Panel Door Open Interlock Detects opening of the panel door by adding a limit switch. Medium-voltage power shutdown command is output on detecting opening.	-	
Separate Installation Type	USB Copy Unit JVOP-181 Enables the copying and transfer of parameters between drives using (one-touch) simple operations. This unit can also be used as a conversion connector between the communication port (RJ-45) of an drive and a USB port of a PC running DriveWizard Plus MV. This option comprises a copy unit with USB interface, an RJ-45 cable and a USB cable.	KAEPC71061622	
	Lifter for Replacing Power Cells Facilitates power cell replacement.	-	
	Inrush Current Suppression Circuit Suppresses the inrush current on turning the drive power on by adding a suppression circuit.	Under development	

\*1: Only one optional communication card can be selected.

\*2: To apply PG control, the PG speed control card must be selected.

## Fans, Blowers, Pump Equipment (Variable Torque Load)



### 1. Energy-saving operation

- Switching operation from conventional damper (valve) control using a commercial power supply to frequency control with FSDrive-MV1000 saves a large amount of energy.
- Even bigger energy savings are possible with machines with standby operation (under normal duty conditions).

### 2. Stable operation

- The speed can be retrieved quickly by speed search function in response to momentary power losses.\*
- KEB function allows operation to continue without base-blocking even when momentary power losses occur.
- When priority is given to continuing operation, fault restart function enables FSDrive-MV1000 to continue running even if an unexpected error is detected.

\*: A UPS unit is required in addition to supply control power.

### 3. Achievement of ideal operation patterns

- Because the airflow (flow rate) is controlled directly by the drive output frequency, with none of the pressure loss by dampers (valves), the ideal operation pattern can be achieved easily.
- The machine can be started and stopped frequently.
- With speed search function, operation can be smoothly restarted even when fans are coasting.
- Minimum frequency setting function prevents pumps from failing to supply, meaning that stable supply can be maintained.

### 4. Extended machine life

- The machine runs at low speed during no-load operation, helping to prolong its life.
- Machine life can be further extended by operation methods that minimized impact on the machine by using FSDrive-MV1000 to attain soft starting and soft stopping.

### 5. Reduced power supply capacity

- With FSDrive-MV1000 the accel/decel time can be set as required, and the starting current can be cut substantially. This means that power supply capacity can be reduced.

## General Industrial Machinery (Constant Torque Load)

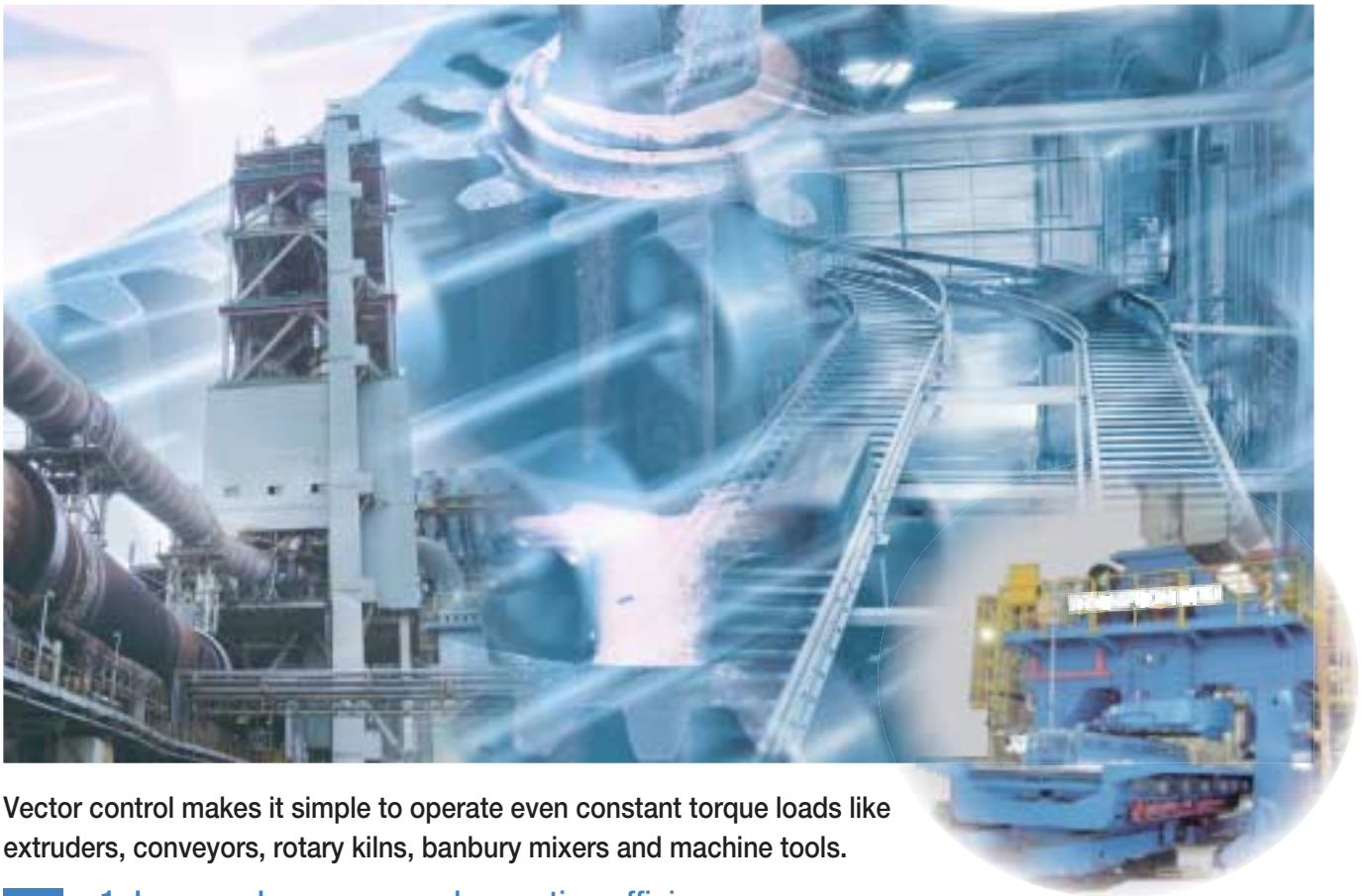

Vector control makes it simple to operate even constant torque loads like extruders, conveyors, rotary kilns, banbury mixers and machine tools.

### Advantages

#### 1. Improved response and operating efficiency

- High starting torque required for operation is provided.
- Vector control improves response against load fluctuations, enabling stable operation.
- Starting current can be kept lower than with direct-on-line, enabling frequent stopping and starting and efficient operation.

#### 2. Improved speed control accuracy

- High-accuracy speed control allows application to machines that demand accuracy, which was difficult with variable speed systems using conventional rotor resistance control.

#### 3. Energy-saving effects

- Using frequency control instead of rotor resistance control of conventional fluid-coupling and wound rotor motors eliminates loss in low-speed operations and saves energy.

#### 4. Better maintainability

- Using a squirrel-cage motor with drive control enables better maintainability than conventional wound rotor motors with rotor resistance control.
- Using drives instead of fluid couplings simplifies the drive system and considerably reduces mechanical maintenance.



Others



Example 1: Commercial power backup system

**Introduce a drive with existing equipment.**

- The existing equipment (breakers, cables, etc.) for commercial power operation can be reused as a backup circuit. (For new installations, switchgears and reactors are available from Yaskawa.)

Example 2: Drive backup system

**For machine with large GD<sup>2</sup>, the total cost is reduced with drive backup**

- The motor is not started by commercial power, so the size of the motor frame is smaller, enabling cost reductions and space savings.
- The system can be run by the backup drive in an emergency. (When using commercial power operation for an application of large GD<sup>2</sup>, a substantial motor frame is needed and this increases the cost.)

Example 3: Achieving variable speed control of an existing wound rotor motor

**System of existing wound rotor motor + medium-voltage drive**

Drives can be put to use with wound rotor motors too.

- Achieves energy savings.
- The existing motor and cables are reused.
- Maintenance of motor brushes and resistors is not necessary.

Short the secondary side of the existing wound rotor motor.

Example 4: Synchronization switching system for synchronous motors

Application to synchronous motors is possible. This system uses a drive to start a synchronous motor and switches shocklessly to the commercial power operation after acceleration is completed. The magnetic pole position is detected before starting the synchronous motor. After reaching the rated motor speed, the voltage phase and amplitude of the drive output are matched before switching to the commercial power supply. (This transfer system can also be applied to induction motors.)

# Standard Connections Diagram

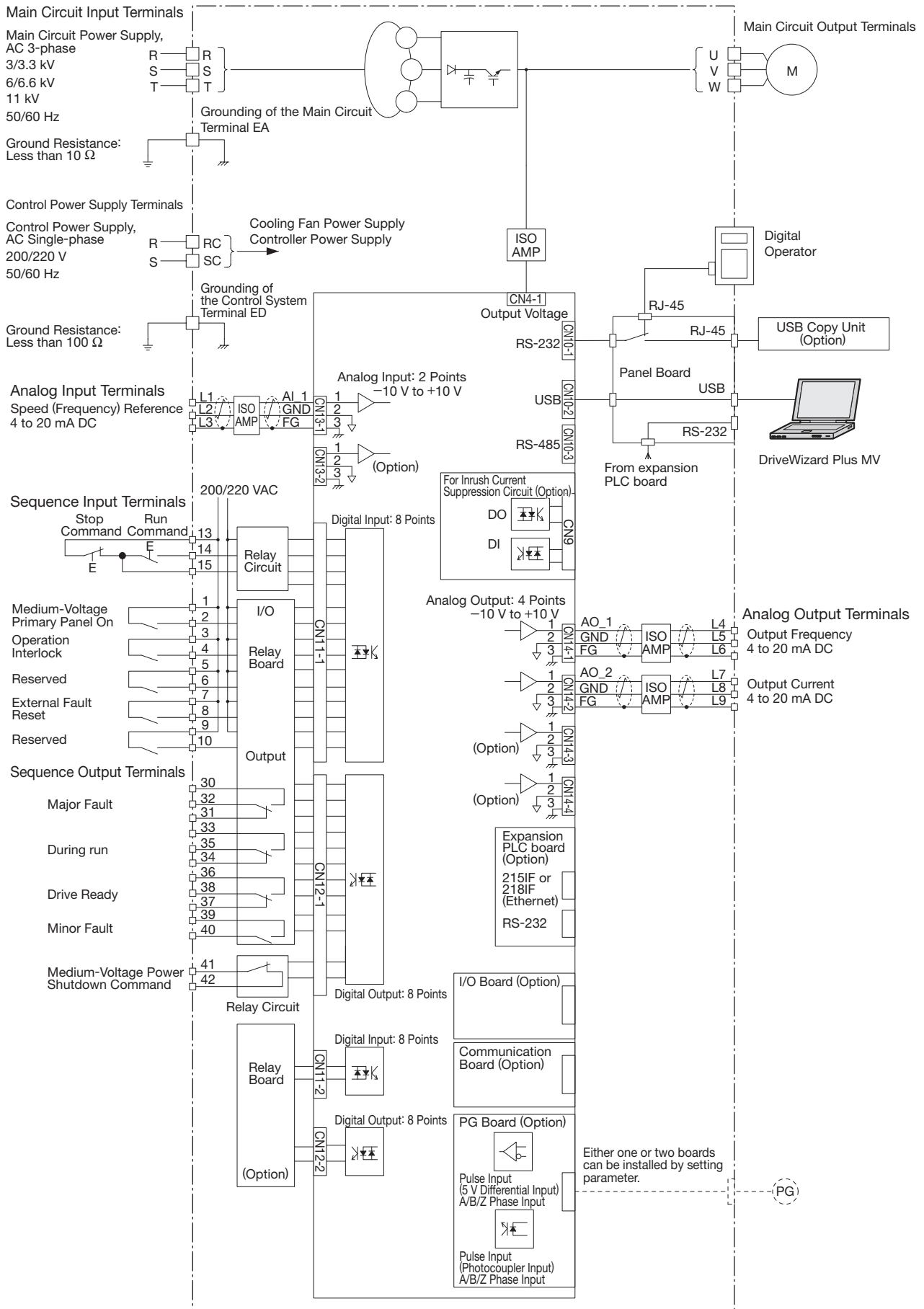

## ● Main Circuit Terminals (Common to all models)

Type	Terminal No.	Terminal Function
Main Circuit Input Terminals	R	3000/3300 VAC, 6000/6600 VAC, 10000 VAC/10500 VAC/11000 VAC 50/60 Hz
	S	
	T	
Main Circuit Output Terminals	U	3000/3300 VAC, 6000/6600 VAC, 10000 VAC/10500 VAC/11000 VAC 50/60 Hz
	V	
	W	
Ground Terminal	EA	Grounding of the main circuit
Control Power Supply Input Terminal	RC	200/220 VAC
	SC	50/60 Hz
Ground Terminal	ED	Grounding of the control system

## ● Control Circuit Terminals (Common to all models)

Type	Terminal No.	Signal Name	Signal Level	Terminal Function
Analog Input Terminals	L1	Speed (Frequency) Reference	4 to 20 mA DC/0 to 60 Hz	Speed (frequency) reference input signal
	L2			Ground
	L3			Shield ground
Analog Output Terminals	L4	Output Frequency	4 to 20 mA DC/0 to 60 Hz	Output frequency reference output signal
	L5			Ground
	L6			Shield ground
	L7	Output Current	4 to 20 mA DC/0 to 150%	Output current reference output signal
	L8			Ground
	L9			Shield ground
Sequence Input Terminals	1	Medium-Voltage Primary Panel On	Contact input 220 VAC/8 mA	ON: Turning on (closed at default)
	2			
	3	Operation Interlock	Contact input 220 VAC/8 mA	ON: Established (closed at default)
	4			
	5	Reserved	—	—
	6			
	7	External Fault Reset	Contact input 220 VAC/8 mA	ON: Reset
	8			
	9	Reserved	—	—
	10			
13	Run Command/ Stop Command	Contact input 220 VAC/8 mA	ON: Run	
14				
15				OFF: Stop
Sequence Output Terminals	30	Major Fault	Transfer contact relay 220 VAC/15 A, 110 VAC/15 A, 24 VDC/15 A	Open: Major Fault (32-31) Closed: Major Fault (32-30)
	31			
	32			
	33	During run	Transfer contact relay 220 VAC/15 A, 110 VAC/15 A, 24 VDC/15 A	Closed: During run (35-33) Open: During run (35-34)
	34			
	35			
	36	Drive Ready	Transfer contact relay 220 VAC/15 A, 110 VAC/15 A, 24 VDC/15 A	Closed: Drive Ready (38-36) Open: Drive Ready (38-37)
	37			
	38			
	39	Minor Fault	N.O. contact relay 220 VAC/15 A, 110 VAC/15 A, 24 VDC/15 A	Closed: Minor Fault
40				
41	Medium-Voltage Power Shutdown Command	N.C. contact output 220 VAC/4 A, 110 VAC/7 A 200 VDC/4 A, 100 VDC/7 A	Closed (N.C.) : Turning off (closed when power is off)	
42				

# Software Functions

Loaded with a variety of software functions, enabling system optimization to your application



Indicates software functions new to FSDrive-MV1000, contrasting them with the existing FSDrive-MV1S.

Note: Only major functions are presented here.

## Functions at Start and Stop

Optimal Deceleration

**Optimal deceleration without needing to set the deceleration time.**

Drive slows the application smoothly controlling DC bus voltage.

**NEW**  
High Slip Braking

**Suitable for applications with occasional stopping, such as emergency stopping of large-inertia loads**

Reduces the deceleration time at emergency stops.

Note: The result may vary depending on conditions such as motor characteristics.

Speed Search

**Start a coasting motor.**

Automatically brings a coasting motor back to the target frequency without using a motor encoder.

**NEW**  
Dwell Function

**Accelerate and decelerate smoothly with large inertia loads.**

Drive prevents speed loss by holding the output frequency at a constant level during acceleration and deceleration.

Accel/Decel Time Switch

**Switch easily between accel/ decel times.**

Switch acceleration and deceleration rates when running two motors from the same drive, or assign specific accel/decel rates when operating at high speed or at low speed.

Direct Current Braking at Start

**Braking the motor by applying direct current when starting**

Enables stopping of a coasting motor for restarting or quickly generating motor magnetic flux (initial excitation) to obtain high starting torque.

## Reference Functions

Frequency Reference Upper/Lower Limits

**Limit motor speed.**

Set speed limits and eliminate the need for extra peripheral devices and extraneous hardware.

Frequency Jump

**Skip over troublesome resonant frequencies.**

Drive can be programmed to avoid machine resonance problems by avoiding constant speed operation at certain speeds.

Frequency Reference Hold

**Improved operability.**

Momentarily hold the operating frequency during acceleration or deceleration as the load is lowered or raised.

**NEW**  
Droop Control

**Balances the load automatically between motors.**

Calculates the ratio of the load torque and adjusts motor speed accordingly.

## Functions for Top Performance

**NEW**  
IM/SM Compatible

**Supporting both IMs and SMs**

Runs wound rotor synchronous motors (SM) as well as induction motors (IM).

Line/Drive Transfer

**Transfer from line to drive, drive to line\***

Perform transfer operation from line to drive and drive to line without stopping motors

\*: An input voltage/current detector needs to be added.

Energy Saving

**Automatically runs at top efficiency.**

The drive supplies voltage to the motor relative to the speed and load so that the application is for operating at the most efficient level.

Current Vector Control

**Achieve high levels of performance.**

The drive comes with current vector control capabilities for high performance applications.

Multi-speed Operation

**Multi-speed operation is possible.**

Enables speed selection in up to 17 steps. Speed selection is even possible during operation by using multi-function digital inputs.

NEW

PID Control

**Automatic PID control**

The internal PID controller fine-tunes the output frequency for precise control of pressure, flow, or other variables.

NEW

Motor 2 Switch

**One drive runs two motors.**

Use a single drive to operate two different motors. Cannot be used with PM motors.

V/f Control (Multi-motor Drive)

**Controlling multiple motors**

Runs multiple motors simultaneously in parallel.

Overtorque Detection

**Improving reliability in continuous operation while protecting the system**

Shuts off the overtorque signal when the motor torque goes beyond the overtorque detection level. This signal can be utilized as an interlock signal to protect the system.

Torque Limit

**Improving reliability in continuous operation while protecting the system**

Helps protect the system by restricting motor torque to a preset level. The output frequency is controlled according to the overload status.

NEW

Timer Function

**No need for extra hardware**

Control timing by opening and closing the output signal relative to the input signal.

Continuos Run during Reference Loss

**Keeps the application running**

Maintains continuous operation even if the controller fails and the frequency reference is lost.

Fault Retry

**Improving reliability in continuous operation**

Resets the system automatically after performing self-diagnostics when the drive detects an error. A number of retries up to 10 can be selected.

Protective Functions

Momentary Power Loss Compensation

**Keep running even during a momentary power loss\***

Automatically restarts the motor and keeps the application running even during a momentary power loss.

\*: A UPS unit is required in addition to supply control power.

Excessive Deceleration Prevention

**Preventing motor stall due to overvoltage**

Controls the deceleration rate automatically by monitoring the DC-bus voltage to prevent overvoltage during deceleration.

Load Speed Display

**Monitor actual speed of the motor and load.**

Monitors let the user keep track of motor rotations and line speed.

NEW

Copy Function

**Save parameter setting to the digital operator.**

Copy all parameter settings to the operator keypad, and then transfer those settings to another drive. Saves valuable setup and maintenance time.

KEB Function

**Continuous operation even during a momentary power loss without base-blocking\***

Uses regenerated energy from the motor to bring the application to a stop rather than simply letting it coast.

\*: A UPS unit is required in addition to supply control power.



# Protective Functions

## ● Drive Faults

Fault	Display	Meaning
DC Bus Undervoltage	Uv1	The average DC voltage of the main circuit for power cells fell lower than the value set in L2-05 (main circuit undervoltage (Uv) detection level).
Ground Fault	GF	The ground-fault current at the drive output side exceeded 50% of the rated output current of the drive.
Voltage Unbalance	VUB	The total value of the output voltage for the three phases exceeded the detection level for longer than the stipulated time.
Output Phase Loss	LF	An open-phase occurred at the drive output. (Detected when L8-07 is set to 1 or 2.)
Transformer Temperature Fault	TME	The temperature input from the transformer exceeded the operation level.
Fan Fault	FAn	A fault on the drive cooling fan has been detected.
Motor Overload	oL1	The motor overload protection function has operated based on the internal electronic thermal value.
Drive Overload	oL2	The drive overload protection function has operated based on the internal electronic thermal value.
Overtorque Detection 1	oL3	There has been a current greater than the setting in L6-02 (overtorque/undertorque detection level 1) for longer than the time set in L6-03 (overtorque/undertorque detection time 1).
Overtorque Detection 2	oL4	There has been a current greater than the setting in L6-05 (overtorque/undertorque detection level 2) for longer than the time set in L6-06 (overtorque/undertorque detection time 2).
Undertorque Detection 1	UL3	There has been a current below the setting in L6-02 (overtorque/undertorque detection level 1) for longer than the time set in L6-03 (overtorque/undertorque detection time 1).
Undertorque Detection 2	UL4	There has been a current below the setting in L6-05 (overtorque/undertorque detection level 2) for longer than the time set in L6-06 (overtorque/undertorque detection time 2).
Overspeed	oS	The speed detection value based on pulse inputs exceeded the value set in F1-08 (overspeed detection level).
PG Disconnect	PGo	The speed detection value based on pulse inputs stayed at 0 for the time set in F1-14 (PG disconnection detection time).
PG Hardware Fault (detected when using a PG-X3 option card)	PGoH	Disconnection of the PG cable has been detected (only when equipped with PG-X3).
Speed Deviation	dEv	The deviation between the speed detection value based on pulse inputs and the speed reference exceeded the value set in F1-10 (excessive speed deviation detection level) for longer than the time set in F1-11 (excessive speed deviation detection time).
Control Fault	CF	The torque limit has been reached continuously for 3 seconds or longer during deceleration to a stop under open-loop vector control.
PID Feedback Loss	FbL	The PID feedback input went below the fault detection level for longer than the set time (detected when b5-12 is set to 2).
External Fault	EF□□	An external fault signal has been input from a multi-function contact input terminal (S□□). (□□: External input number)
MEMOBUS/Modbus Communication Error	CE	Control data has not been received for longer than the time set in H5-09 (CE detection time) after being successfully received once.
Option Card Connection Error	oF□□□	A fault related to an option card has been detected. (□□: fault number, details of the fault)
Control Circuit Error	CPF□□	A fault related to the controller has been detected. (□□: fault number, details of the fault)
Digital Operator Connection Fault	oPr	The connection to the digital operator was broken during operation in response to a run command from the digital operator.
CCB-MB Communications Error (Link fault)	□□: LIN	Response data from power cells have not been detected for longer than the set detection time.

## ● Power Cell Faults

Fault	Display	Meaning
Overcurrent	CFA □□: OC	An output current greater than the specified overcurrent level has been detected.
Overvoltage	CFA □□: OV	The DC voltage at the P side or N side of the main circuit exceeded the overvoltage detection level.
Undervoltage	CFA □□: CUV	The DC voltage at the P side or N side of the main circuit fell below the undervoltage detection level.
Excessive Temperature	CFA □□: OH	The temperature detection value exceeded the fault detection level.
Main Circuit Capacitor Neutral Point Potential Error	CFA □□: VCF_OV	The DC voltage at the P side or N side of the main circuit became unbalanced.
IGBT Fault	CFA □□: IGBT_FLT	An IGBT fault (arm short-circuit, output short-circuit, or circuit fault) has been detected.
Fuse Blowout	CFA □□: FU	Blowout of a main circuit fuse or open-phase in the input voltage has been detected.
Thermistor Disconnect	CFA □□: THBOW	The temperature detection value fell to the thermistor disconnect detection level or lower.

□□: fault power cell number

## Examination of capacity 1

### For blower motor

When commercial power operation method is changed to speed control method, the applicable drive capacity is determined as follows.

Example: Motor rating: 500 kW, 4P, 3 kV at 50 Hz

Assuming that:

- Motor rated current : 120 A
- Maximum value of actual operation load current : 95 A

For this applicable drive capacity, rated current 100A (nominal capacity 570 kVA) should be selected. (100 A > 95 A)

## Examination of capacity 2

### For extruder motor

Example: Motor rating: 400 kW, 6P, 3.3 kV at 60 Hz

Assuming that:

- Motor rated current: 88 A
- Required overload tolerance: 120% for 60 seconds

The applicable drive tolerance is shown below considering the allowance of 10%:

$$88 \text{ A} \times 1.3 = 115 \text{ A}$$

Therefore, for this applicable drive capacity, rated current 140 A (nominal capacity 800 kVA) should be selected. (140 A > 115 A)

## Examination of capacity 3

### For cement kiln motor

Example: Motor rating: 500 kW, 6P, 6.6 kV at 60 Hz

Assuming that:

- Motor rated current: 53 A
- Required overload tolerance: 250% for 60 seconds

The applicable drive capacity is shown below considering the allowance of 10%:

$$53 \text{ A} \times 2.6 = 138 \text{ A}$$

Therefore, for this applicable drive capacity, rated current 140 A (nominal capacity 1600 kVA) should be selected. (140 A > 138 A)

## Motors for Medium-Voltage Drives

The rated output described in the following table is when a motor with 4 poles and 60 Hz is selected.

Structure and Model	Protective Structure, Cooling Method	Rated Voltage	Rated Output (kW)			
			110	1,000	5,000	10,000
<b>Variable Torque Series: Self-ventilated Type</b>						
Drip-proof Protected Type BDK-I	IP-22,	6kV	315		7,100	
	IC-01	3kV	450		8,000	
Totally-enclosed Fan-cooled Type FEK-I	IP-44,	6kV	55	1,250		
	IC-411	3kV	37	1,400		
Totally-enclosed Internally-cooled, with Motor-mounted Air-cooled Heat Exchanger Type HEK-I	IP-44,	6kV	355		5,600	
	IC-611	3kV	560		6,300	
<b>Constant Torque Series*: Externally Fan-cooled Type</b>						
Drip-proof Protected Type BDK-IKM	IP-22,	6kV	315		7,100	
	IC-06	3kV	450		8,000	
Totally-enclosed Fan-cooled Type FEK-IKM	IP-44,	6kV	250	1,250		
	IC-416	3kV	315	1,400		
Totally-enclosed Internally-cooled, with Motor-mounted Air-cooled Heat Exchanger Type EKK-IM	IP-44,	6kV	355		5,600	
	IC-666	3kV	560		6,300	

\* : The motors of constant torque series include a PLG or a motor using a forced-air cooling fan.

### Accessories (Option)

- Stator winding temperature detectors: Resistance temperature detector (RTD)
- Bearing temperature detectors: Dial thermometer, Resistance temperature detector (RTD)
- Space heater



Totally-enclosed, fan-cooled type FYT series  
For details, refer to the catalog No. KAEP26020000.



Totally-enclosed internally-cooled, with motor-mounted air-cooled heat exchanger type NB series  
For details, refer to the catalog No. KA-C280-4 (English version).

## Notes on Using Drives

### Selection

#### ■ Power Supply Capacity

The power supply to be connected to the drive should have a capacity larger than the power required by the drive with the power factor and efficiency taken into account. When connecting multiple drives to a single power supply, select a power supply with a capacity larger than the sum of the power required by all the drives to be connected. Even when the power supply has sufficient capacity, the power supply voltage may drop when the power is turned on, causing malfunction of connected devices if the power supply has a large power impedance.

#### ■ Drive Capacity

When running multiple induction motors in parallel using a single drive, the capacity of the drive should be larger than 1.1 times the total motor rated current.

#### ■ Starting Torque

The overload current rating of the drive determines the starting and acceleration characteristics of the motor. Generally, lower torque characteristics on starting are expected when compared to using a commercial power supply. For applications that require high starting torque, select an drive with a larger capacity.

#### ■ Emergency Stop

When the drive faults out, a protective function is activated and drive output is shut off. This, however, does not stop the motor immediately. Some type of mechanical brake may be needed if it is necessary to halt the motor faster than the Fast Stop function is able to.

### Installation

#### ■ Ambient Environment

Keep the drive in a clean environment that is free from airborne oil mist, corrosive gas, flammable gas, lint and dust. Install the fan cover at the top of the panel before starting operation. Any modification to the outside of the panel cooling fan, such as connecting a duct, may reduce air flow for cooling and cause overheating and faults. Do not use a duct.

#### ■ Drive Storage

When storing the drive as is in a storage facility or in the installed state, observe the following points to maintain its reliability.

- Short term storage of the drive  
Short term storage refers to cases where the drive is stored for up to one month after unpacking or up to three months after shipping. Secure a storage environment that satisfies the conditions cited for the drive's environmental specification. Note that an ambient temperature of up to 60°C is acceptable.
- Long term storage of the drive  
Long term storage refers to cases where the drive is stored for more than one month after unpacking or more than three months after shipping. Contact Yaskawa if long term storage is required. Note that an ambient temperature of up to 50°C is acceptable.
- Store the spare parts without unpacking them. For details, refer to the storage method described in the Instruction Manual.

#### ■ Grounding Specification

Provide a dedicated grounding(EA) of less than 10  $\Omega$  for the main circuit of the drive and a dedicated grounding(ED) of less than 100  $\Omega$  for the control circuit.

#### ■ Compliance with local laws

Please comply with the law of the relevant country when you install this product.

#### ■ Effects of Distortion in Power Supply

When the power supply voltage is originally distorted, or when multiple devices and the drive are connected to the same power supply, drive harmonics from the power supply system flow into the drive, resulting in high relative harmonic content.

### Settings

#### ■ Use V/f control when running multiple induction motors using a single drive.

#### ■ Upper Limits

The drive is capable of running the motor at up to 120 Hz. Incorrect settings might result in dangerous operating conditions, so be sure to set the upper limit for the frequency to control the maximum speed. (The maximum output frequency for operation by external input signals is set to 60 Hz by default.)

#### ■ Accel/Decel Times

Accel and decel times are determined by the torque that the motor generates, the load torque and the inertia moment ( $GD^2$ ). Set a longer accel/decel time when the stall prevention function is activated during accel/decel. When the stall prevention function is activated, the accel/decel time is extended to cover the time that the function operates. To achieve even faster acceleration and deceleration, select motors, and a drive, with greater capacity.

### General Handling

#### ■ Wiring Check

Never short the output terminals of the drive or apply voltage from the power supply to the output terminals (U, V, W). This will damage the drive. Carry out wiring that conforms to the wire sizes and tightening torques described in the Instruction Manual. Conduct a thorough check of wiring errors before turning the power on.

#### ■ Breaker/Magnetic Contactor Selection and Installation

Select a breaker with sufficient capacity for the power supply side of the drive, taking the inrush current from the transformer into account. Avoid using the breaker or magnetic contactor for frequent starting/stopping. This may damage the drive. Do not switch the breaker/magnetic contactor ON/OFF more than twice a day. If it is operated more frequently, install an optional inrush current suppression circuit between the power supply and the drive. Use a low-surge type Vacuum Circuit Breaker for drive primary side breaker.



### ■ Inspection and Maintenance

Even after shutting off the drive, it takes some time to discharge of internal capacitors. Make sure that the CHARGE light has gone out completely before performing any inspection or maintenance work. With residual electric charge in the capacitors, the resulting high voltage in the power cell and on its surface can cause electric shock.

The heatsink of the power cell can become quite hot during operation, and proper precautions should be taken to prevent burns.

When replacing the cooling fan, wait at least 15 minutes after shutting off the power and make sure that the cooling fan has fully stopped before starting the work.

### ■ Transportation/Installation

Never steam clean the drive.

During transportation and installation, the drive must never be exposed to an atmosphere containing a halogen gas such as fluorine, chlorine, bromine, or iodine.

### ■ Hoisting

With some large capacity drives, the transformer, rather than the transformer panel itself, must be hoisted directly. The drive may deform or fall down if the drive panel frame is hoisted. For details, refer to the installation method described in the Instruction Manual.

### ■ Radio Frequency Interference

Inputs and outputs of the drive (main circuit) contain harmonic components that may adversely affect communication devices, such as AM radios, used in the vicinity. Use high-voltage cables and ground any shielded cables. Separate cables for control from high-current circuits (main circuit and relay sequence circuits) to avoid induction from peripheral devices. (It is advisable to separate them by a distance of 30 cm or more.)

### ■ Leakage Current

Harmonic leakage current passes through stray capacitance between the drive power lines, ground and the motor lines. Consider taking measures against this leakage current.

## Notes on Motor Operation

### Application to Existing Standard Motors

#### ■ Insulation Tolerance

Consider voltage tolerance levels and insulation in applications with high input voltage or particularly long wiring distances.

Contact Yaskawa for consultation.

#### ■ High Speed Operation

Running a motor beyond its rated speed may lead to problems imposed by vibration or the durability of motor bearings. Contact the manufacturer of the motor for details.

#### ■ Torque Characteristics

When driven by a drive, the torque characteristics of the motor differ from when it is driven with a commercial power supply. Therefore, the load torque characteristics that the motor drives need to be confirmed.

#### ■ Vibration and Shock

The PWM control with multiple outputs connected in series of FSDrive-MV1000 reduces motor oscillation to the same level as in operation by commercial power supply. However, the motor oscillation is slightly larger due to the following factors.

##### (1) Resonance with the natural frequency of the mechanical system

Take particular caution when using a variable speed drive for an application that is conventionally run by commercial power at a constant speed. Installing shock absorbing rubber under the base of the motor and using Frequency Jump function can be effective measures.

##### (2) Residual unbalance of the rotating motor

Particular care is required when running the motor beyond its rated speed.

##### (3) Subsynchronous Resonance

Subsynchronous resonance may occur in fans, blowers, turbines, and other applications with high load inertia, as well as in motors with a relatively long shaft.

Yaskawa recommends using the closed loop vector control for such applications.

# Inquiry Form

Please specify the following information when inquiry.

1	Name of facility or application			
2	Name of load	<input type="checkbox"/> Pump <input type="checkbox"/> Fan <input type="checkbox"/> Blower <input type="checkbox"/> Compressor <input type="checkbox"/> Extruder <input type="checkbox"/> Others		
3	Load characteristics	<input type="checkbox"/> Variable torque <input type="checkbox"/> Constant torque	<input type="checkbox"/> Proportional torque <input type="checkbox"/> Constant output	GD <sup>2</sup> _____ kg·m <sup>2</sup>
4	Operation conditions	Motor Current _____ A	Operation time Annual _____	hours _____
5	Motor model to be driven	<input type="checkbox"/> Squirrel-cage motor <input type="checkbox"/> Wound rotor motor <input type="checkbox"/> Synchronous motor		<input type="checkbox"/> Existing <input type="checkbox"/> New
6	Motor specifications	Output _____ kW	Voltage _____ V	Frequency _____ Hz
		Number of poles _____ p	Speed _____ min <sup>-1</sup>	
		Rated current _____ A	Efficiency _____ %	Power factor _____
7	Speed control range	Minimum _____ min <sup>-1</sup> to Maximum _____ min <sup>-1</sup> or Minimum _____ Hz to Maximum _____ Hz		
8	Speed setting procedure	<input type="checkbox"/> Process signal 4 to 20 mA operation <input type="checkbox"/> Manual rotating speed adjusting operation <input type="checkbox"/> UP/DOWN signal adjusting operation <input type="checkbox"/> Multi-step speed signal changeover operation		
9	Pattern operation (with/without)	<input type="checkbox"/> Acceleration time _____ Second(s)/ _____ min <sup>-1</sup> <input type="checkbox"/> Deceleration time _____ Second(s)/ _____ min <sup>-1</sup>		
10	Overload tolerance	_____ %/ _____ Second(s)		
11	Commercial power supply by-pass operation circuit	<input type="checkbox"/> Not needed <input type="checkbox"/> Needed <Drive to line <input type="checkbox"/> Automatic changing method <input type="checkbox"/> Manual changing method>		
12	Power supply specifications	Main circuit power supply capacity _____ kVA	Main circuit voltage _____ V	Frequency _____ Hz
		Control circuit voltage <input type="checkbox"/> 200/220V <input type="checkbox"/> 400/440V		
13	Ambient conditions	Indoors <input type="checkbox"/> Ambient temperature _____ °C to _____ °C <input type="checkbox"/> Humidity _____ % or less <input type="checkbox"/> Air-conditioning facility (Provided/Not provided)		



Region	Service Area	Service Location	Service Agency	Telephone/Fax
North America	Canada	Montreal	① YASKAWA MOTOMAN CANADA LTD.	☎ +1-514-693-6770 FAX +1-514-693-9212
Central America	Mexico, Belize, Guatemala, Honduras, El Salvador, Nicaragua	Mexico City	② PILLAR MEXICANA. S.A. DE C.V.	☎ +52-555-660-5553 FAX +52-555-651-5573
South America	Argentina, Chile, Bolivia, Paraguay, Uruguay	Buenos Aires	③ Elinsur S.R.L.	☎ +54-11-4918-2056 FAX +54-11-4918-1183
	Brasil	São Paulo	④ YASKAWA ELÉTRICO DO BRASIL LTDA.	☎ +55-11-3585-1100 FAX +55-11-5581-8795
	Panama, Costa Rica, Colombia, Venezuela, Peru, Ecuador	Bogota	⑤ Variadores S.A.	☎ +57-1-428-4225 FAX +57-1-428-2173
Europe	Europe, South Africa	Frankfurt	⑥ YASKAWA EUROPE GmbH	☎ +49-6196-569-300 FAX +49-6196-569-398
Asia, Oceania	Japan	Tokyo, offices nationwide	⑦ YASKAWA ELECTRIC ENGINEERING CORPORATION	☎ +81-4-2931-1810 FAX +81-4-2931-1811
	South Korea	Seoul	⑧ YASKAWA ELECTRIC KOREA CORPORATION	☎ +82-2-784-7844 FAX +82-2-784-8495
	China	Shanghai (HQ), Beijing, Guangzhou, Chengdu	⑨ YASKAWA ELECTRIC (SHANGHAI) Co., Ltd.	Headquarters ☎ +86-21-5385-2200 FAX +86-21-5385-3299
	Taiwan	Taipei	⑩ YATEC ENGINEERING CORPORATION	☎ +886-2-6635-7030 FAX +886-2-2298-7010
	East Asia, Oceania	Singapore	⑪ YASKAWA ELECTRIC (SINGAPORE) Pte. Ltd.	☎ +65-6282-3003 FAX +65-6289-3003
	Thailand	Bangkok	⑫ YASKAWA ELECTRIC (THAILAND) Co., Ltd.	☎ +66-2-693-2200 FAX +66-2-693-4200
	India	Mumbai	⑬ LARSEN & TOUBRO LIMITED	☎ +91-22-67226200 +91-22-27782230 FAX +91-22-27783032
	Indonesia	Jakarta	⑭ PT. YASKAWA ELECTRIC INDONESIA	☎ +62-21-57941845 FAX +62-21-57941843

# FSDrive-MV1000

---

## **TOKYO OFFICE**

New Pier Takeshiba South Tower, 1-16-1, Kaigan, Minatoku, Tokyo 105-6891 Japan  
Phone 81-3-5402-4502 Fax 81-3-5402-4580  
<http://www.yaskawa.co.jp>

## **YASKAWA MOTOMAN CANADA LTD.**

298 Labrosse Pointe Claire, QC H9R 5L8, Canada  
Phone 1-514-693-6770 Fax 1-514-693-9212  
<http://www.motoman.com>

## **YASKAWA ELÉTRICO DO BRASIL LTDA.**

Avenida Fagundes Filho, 620 São Paulo-SP CEP 04304-000, Brazil  
Phone 55-11-3585-1100 Fax 55-11-5581-8795  
<http://www.yaskawa.com.br>

## **YASKAWA EUROPE GmbH**

Hauptstrasse 185, 65760 Eschborn, Germany  
Phone 49-6196-569-300 Fax 49-6196-569-398  
<http://www.yaskawa.eu.com>

## **YASKAWA ELECTRIC KOREA CORPORATION**

9F, Kyobo Securities Bldg., 26-4, Yeouido-dong, Yeongdeungpo-gu, Seoul 150-737, Korea  
Phone 82-2-784-7844 Fax 82-2-784-8495  
<http://www.yaskawa.co.kr>

## **YASKAWA ELECTRIC (SINGAPORE) PTE. LTD.**

151 Lorong Chuan, #04-01, New Tech Park 556741, Singapore  
Phone 65-6282-3003 Fax 65-6289-3003  
<http://www.yaskawa.com.sg>

## **YASKAWA ELECTRIC (THAILAND) CO., LTD.**

252/246 4th Floor, Muang Thai-Phatra Office Tower 2, Rachadaphisek Road, Huaykwang, Bangkok 10320, Thailand  
Phone 66-2693-2200 Fax 66-2693-4200  
<http://www.yaskawa.co.id/>

## **PT. YASKAWA ELECTRIC INDONESIA**

Menara Anugrah Lantai 1, Kantor Taman E.3.3, Jl. Mega Kuningan Lot 8.6-8.7, Kawasan Mega Kuningan, Jakarta, Indonesia  
Phone 62-21-57941845 Fax 62-21-57941843  
<http://www.yaskawa.com.sg>

## **YASKAWA ELECTRIC (SHANGHAI) CO., LTD.**

12F, Carlton Bldg., No.21 HuangHe Road, HuangPu District, Shanghai 200003, China  
Phone 86-21-5385-2200 Fax 86-21-5385-3299  
<http://www.yaskawa.com.cn>

## **YATEC ENGINEERING CORPORATION**

No.34,Sihyuan Rd.,Sinjhuang City, Taipei Country 242, Taiwan  
Phone 886-2-6635-7030 Fax 886-2-6635-7010



YASKAWA ELECTRIC CORPORATION

In the event that the end user of this product is to be the military and said product is to be employed in any weapons systems or the manufacture thereof, the export will fall under the relevant regulations as stipulated in the Foreign Exchange and Foreign Trade Regulations. Therefore, be sure to follow all procedures and submit all relevant documentation according to any and all rules, regulations and laws that may apply.

Specifications are subject to change without notice for ongoing product modifications and improvements.

© 2011 YASKAWA ELECTRIC CORPORATION. All rights reserved.

LITERATURE NO. KAEP C710687 02C

Published in Japan December 2011 11-5   
11-9-2